



5" x 8" DIRECT VENT INSTALLATION INSTRUCTIONS FOR DECORATIVE GAS APPLIANCES AND DIRECT VENT HEATERS

APPLICATION

These instructions apply to the Simpson Dura-Vent 5" x 8" Direct Vent System. This venting system, in combination with the gas appliance, has been tested and listed as a decorative gas appliance system, or as a direct vent heater system by a major testing agency such as UL, AGA, CGA, Omni or Warnock Hersey. Check the manufacturer's rating plate and instruction manual to confirm that the Simpson Dura-Vent direct vent system is approved for use on the brand name appliance you have selected.

IMPORTANT

Read all instructions carefully before starting the installation. Failure to follow these instructions may create a fire or other safety hazard, and will void the warranty. Be sure to check the appliance manufacturer's installation instructions for specific venting and clearance to combustibles requirements, which may vary from one appliance to another. **Do not extend the venting system vertically or horizontally in excess of the distance prescribed in the appliance manufacturer's installation instructions.**

INSTALLATION PRECAUTIONS

The Simpson Dura-Vent Direct Vent System is an engineered product that has been designed and tested for use with an approved list of direct vent gas appliances. The Simpson Dura-Vent warranty will be voided, and serious fire, health, or other safety hazards may result from any of the following actions:

- Installation of any damaged Direct Vent component.
- Unauthorized modification of the Direct Vent System
- Installation of any component part not manufactured or approved by Simpson Dura-Vent.
- Installation other than as instructed by Simpson Dura-Vent and the appliance manufacturer.

Consult your local building codes before beginning the installation.

WARNING

• **Always maintain required clearances (air spaces) to nearby combustibles to prevent a fire hazard. Do not fill air spaces with insulation.**

Be sure to check the appliance manufacturers's installation instructions for minimum clearance requirements between the outer walls of the vent pipe and nearby combustible surfaces. Be sure to check the vent termination clearance requirements from decks, windows, soffits, gas regulators, air supply inlets, and public walkways, as specified in these installation instructions and local building codes.

• **The gas appliance and vent system must be vented directly to the outside of the building, and never be attached to a chimney serving a separate solid fuel or gas-burning appliance.** Each direct vent gas appliance must use it's own separate vent system. **Common vent systems are prohibited.**

SAFETY PRECAUTIONS FOR THE INSTALLER

- Wear gloves and safety glasses for protection.
- Exercise extreme caution when using ladders or on roof tops.
- Be aware of electrical wiring locations in walls and ceilings.

PARTS LIST

The Simpson Dura-Vent Direct Vent System offers a complete line of component parts for both horizontal and vertical installations. Decorative brass or chrome trim kits are available for both wall thimble covers and ceiling support boxes. Snorkel terminations are available for applications which may require vertical rise on the building exterior.

PARTS LIST

<u>Number</u>	<u>Description</u>
1208B	6" Pipe Length, Black Finish
1207B	9" Pipe Length, Black Finish
1206B	12" Pipe Length, Black Finish
1204B	24" Pipe Length, Black Finish
1203B	36" Pipe Length, Black Finish
1202B	48" Pipe Length, Black Finish
1211B	11" to 14-5/8" Pipe, Adjustable, Black Finish
1217B	17" to 24" Pipe, Adjustable, Black Finish
1245B	45° Elbow, Black Finish
1290B	90° Elbow, Black Finish
1240	Round Ceiling Support / Wall Thimble Cover
1241	Cathedral Ceiling Support Box
1242	Wall Firestop
1243	Flashing, 0/12 to 6/12 Roof Pitch
1243S	Flashing, 7/12 to 12/12 Roof Pitch
1247	Wall Thimble (only required in Canada)
1253	Storm Collar
1263	Ceiling Firestop
1288	Wall Strap
1281	Snorkel Termination (36")
1282	Snorkel Termination (14")
1284	Horizontal Square Termination
1285	Horizontal Square Termination, High Wind
1280	Vertical Termination
1291	Vertical Termination, High Wind
1250	Vinyl Siding Standoff

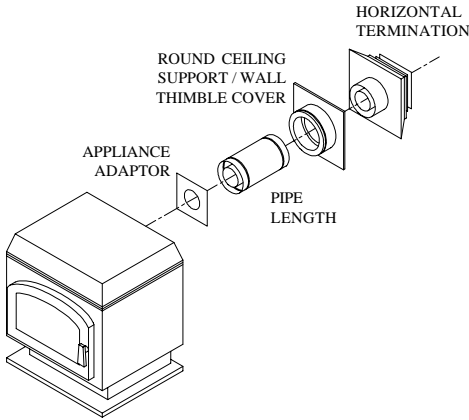

Fig 1

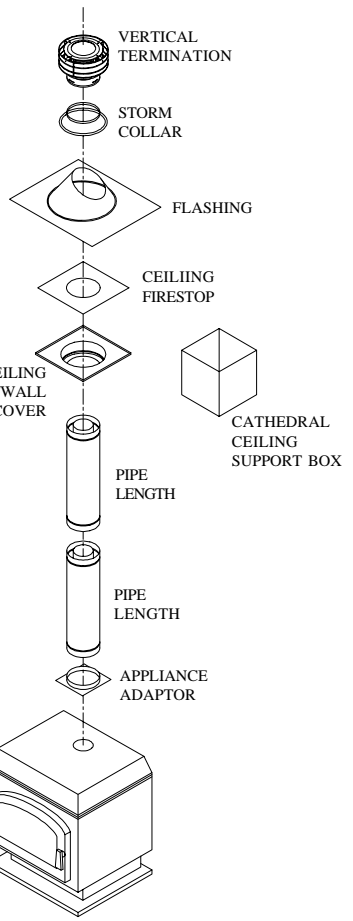

Fig 3

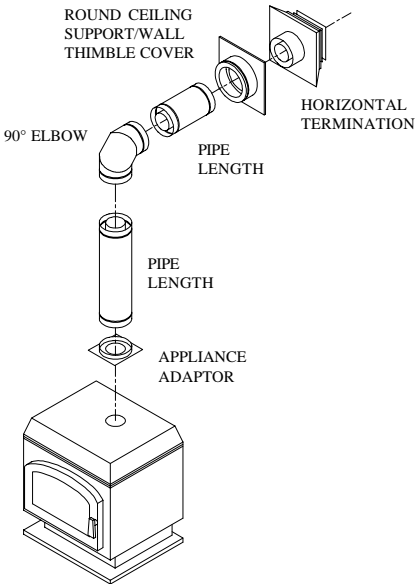

Fig 2

PLANNING YOUR INSTALLATION

There are two basic types of Direct Vent System installations. Check the appliance manufacturer's installation instructions to confirm what types are permitted, and also check for any venting restrictions such as maximum horizontal run, and minimum or maximum vertical rise. The two general types of installations are:

- Horizontal Termination (Figs 1 and 2)
- Vertical Termination (Fig 3)

When planning your installation, it will be necessary to select the proper length of vent pipe for your particular requirements. For horizontal installations, check the appliance manufacturer's installation instructions to determine the minimum clearance from the rear of the appliance to the wall. It is also important to note the wall thickness. Select the amount of vertical rise desired for "vertical-to-horizontal" type installations (verify that it is within the appliance manufacturer's minimum or maximum limits). To determine the length of vent pipe required for vertical installations, measure the distance from the appliance flue outlet to the ceiling, the ceiling thickness, the vertical rise in an attic or second story, and allow for sufficient vent height above the roofline. For two-story applications, firestops are required at each floor level. If an offset is needed in the attic, additional pipe and elbows will be required.

HORIZONTAL INSTALLATION

Step 1. Set the gas appliance in its desired location. Check to determine if wall studs or roof rafters are in the way when the venting system is attached. If this is the case, you may want to adjust the location of the appliance.

Step 2. Direct Vent pipe and fittings are designed with special twist-lock connections. To connect the venting system to the appliance flue outlet, a twist-lock appliance adaptor is required. With some brands of appliances, the Simpson Dura-Vent adaptor will be built into the appliance at the factory. With other brands, it will be supplied by the appliance manufacturer, for installation in the field. Assemble the desired combination of black pipe and elbows to the appliance adaptor with pipe seams oriented towards the wall or floor, as much out of view as possible. If the appliance adaptor is not built into the appliance at the factory, it may be preferable to assemble the pipe and elbows to the adaptor prior to mounting the adaptor onto the stove. In this manner, the pipe and 90° elbow assembly may be properly twist-locked and rotated to face the wall termination, with final positioning

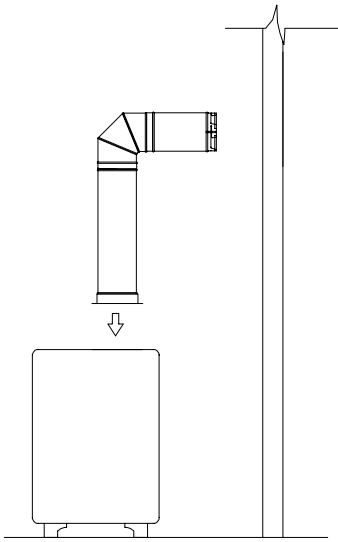

Fig 4

of the vent pipe assembly determined by the mounting orientation of the appliance adaptor onto the stove. (Fig 4)

Notes: (1) Twist-lock procedure: Four indentations, located on the female ends of pipes and fittings, are designed to slide straight onto the male ends of adjacent pipes and fittings, by orienting the four pipe indentations so they match and slide into the four entry slots on the male ends. (Fig 5) Push the pipe sections completely together, then twist-lock one section clockwise approximately one-quarter turn, until the two sections are fully locked. The female locking lugs will not be visible from the outside of the Black Pipe sections. They may be located by examining the inside of the female ends.

(2) Horizontal runs of vent must be supported every three feet. Use Wall Straps or Plumber's Tape / Strapping for this purpose.

(3) Sealant is optional, unless specified by the appliance manufacturer. Should you elect to use sealant, it is only necessary on the outer tube of the Pipe Section. Run a 1/8" wide bead of sealant around the male end of the outer sleeve, as shown in Figure 5, and twist-lock the pipes or fittings together.

Step 3. With the adaptor and pipe attached to the stove, slide the stove into it's correct location, and mark the wall for a square hole of the appropriate size. Use an 11" x 11" square hole when using 5" x 8" pipe. The center of the square hole should line up with the centerline of the horizontal pipe, as shown in Figure 6, unless otherwise required by the appliance manufacturer. Cut and frame the square opening in the exterior wall where the vent will be terminated. If the wall being penetrated is constructed of

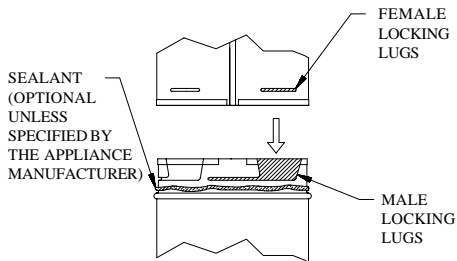

Fig 5

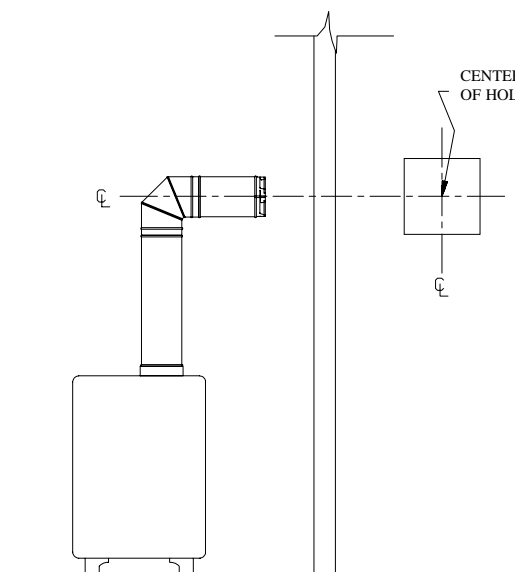

Fig 6

noncombustible material only, i.e. masonry block or concrete only, a hole with zero clearance is acceptable.

Notes:

(1) The horizontal run of vent must be level, or have a 1/4" rise for every 1 foot of run towards the termination. Never allow the vent to run downward. This could cause high temperatures and may present the possibility of a fire.

(2) The location of the horizontal vent termination on an exterior wall must meet all local and national building codes, and must not be easily blocked or obstructed. Termination clearances are as follows:

- (a) Clearance above the ground, veranda, porch, deck or balcony: 12 inches minimum.
- (b) Clearance to a window (openable or fixed closed) or door: 12 inches minimum.
- (c) Vertical clearance to a ventilated soffit located above the termination (if soffit extends a horizontal distance of 2 feet out over the centerline of the termination): 18 inches minimum.
- (d) Clearance to an unventilated soffit: 12 inches minimum.
- (e) Clearance to an outside corner: as tested by appliance mfg.
- (f) Clearance to an inside corner: as tested by appliance mfg.
- (g) Not to be installed above a meter/regulator assembly within 3 feet horizontally from the centerline of the regulator.
- (h) Clearance to a service regulator vent outlet: 6 feet minimum.
- (i) Clearance to non-mechanical air supply inlet to a building or the combustion air inlet to any other appliance: 12 inches minimum.
- (j) Clearance to a mechanical air supply inlet: 6 feet minimum.
- (k) Clearance above a paved sidewalk or paved driveway located on public property: refer to local code.

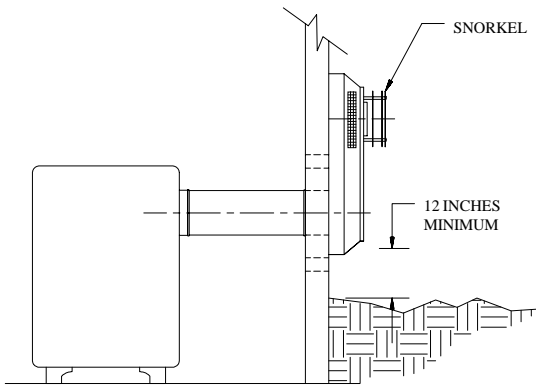

Fig 7

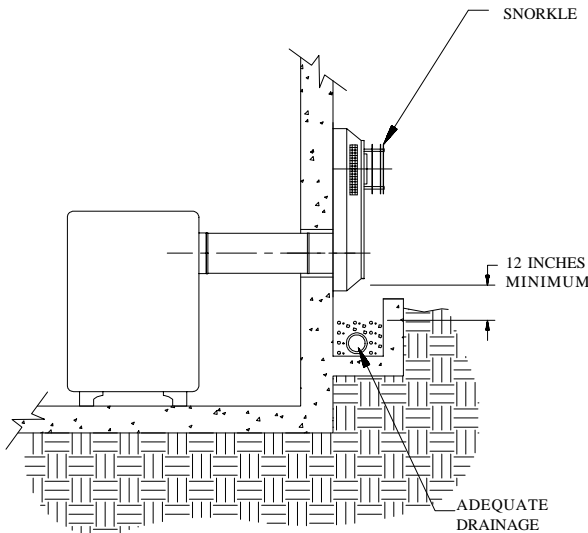

Fig 8

(1) Clearance under a veranda, porch, deck or balcony: 12 inches minimum.

For installations requiring a vertical rise on the exterior of the building, 14-inch and 36-inch tall Snorkel Terminations, as shown in Figure 7 are available. Follow the same installation procedures as used for standard Horizontal Terminations. If the Snorkel Termination must be installed below grade, (i. e. basement application), proper drainage must be provided to prevent water from entering the Snorkel Termination. Refer to Figure 8. Do not attempt to enclose the Snorkel within the wall, or any other type of enclosure.

Step 4. Position the Horizontal Vent Termination in the center of the square hole, and attach to the exterior wall with the four

wood screws provided. Before attaching the vent termination to the exterior wall, run a bead of non-hardening sealant around it's outside edges, so as to make a seal between it and the wall. The arrow on the vent cap should be pointing up. Insure that proper clearances to combustibile materials are maintained. (Fig 9)

Notes:

(1) The four wood screws provided should be replaced with appropriate fasteners for stucco, brick, concrete, or other types of sidings.

(2) For buildings with vinyl sidings, a Vinyl Siding Standoff, should be installed between the vent cap and the exterior wall. (Figure 10). Attach the Vinyl Siding Standoff to the Horizontal Vent Termination. The Vinyl Siding Standoff prevents excessive heat from possibly melting the vinyl siding material. Note that the Horizontal Vent Termination bolts onto the flat portion of the Vinyl Siding Standoff, (shaded area shown in Figure 10), so that an air space will exist between the wall and the Vent Termination. Follow the label on the Standoff for which side of the Standoff faces wall.

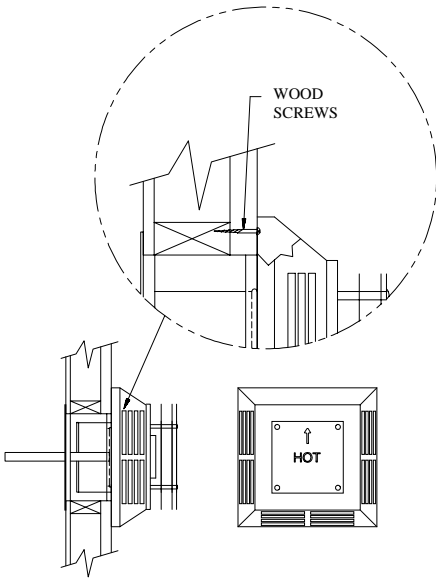

Fig 9

horizontal run of vent pipe to the vent termination, slide the Black Decorative Wall Thimble Cover over the vent pipe.

Step 6. Slide the appliance and vent assembly towards the wall, carefully inserting the vent pipe into the vent cap assembly. It is important that the vent pipe extend into the vent cap a sufficient distance so as to provide a minimum pipe overlap of 1-1/4 inches. Secure the connection between the vent pipe and the vent cap by attaching the two sheet metal strips extending from the vent cap assembly into the outer wall of the vent pipe. Use the two sheet metal screws provided to connect the strips to the Pipe Section. Bend any re-

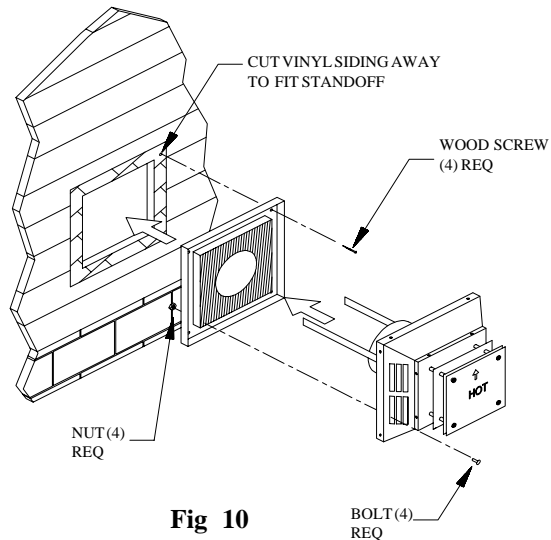

Fig 10

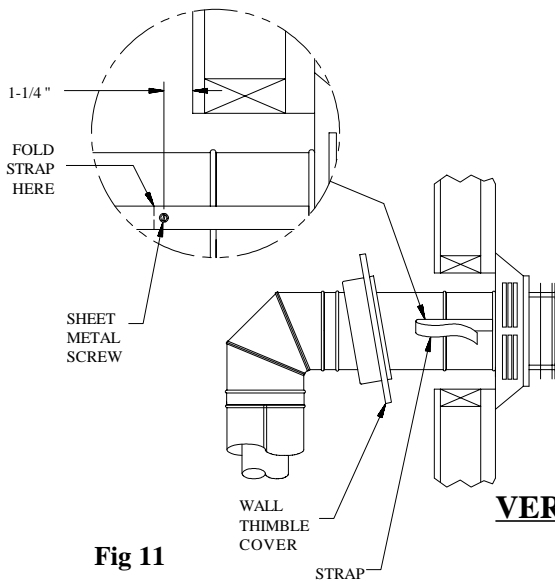

Fig 11

maining portion of the sheet metal strip back towards the vent cap, so it will be concealed by the Decorative Wall Thimble Cover. (Fig 11)

Step 7. Slide the Decorative Wall Thimble Cover up to the wall surface and attach to the wall with screws provided. Apply optional decorative brass or chrome trim if desired. (Fig 12)

VERTICAL TERMINATION

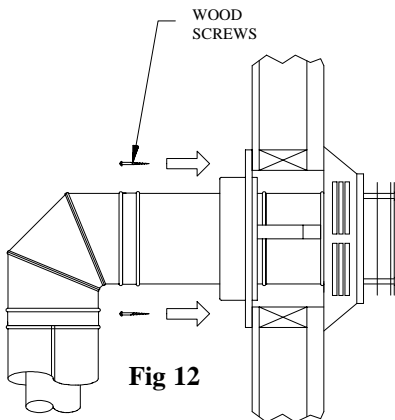

Fig 12

Step 1. Check the appliance manufacturer's installation instructions for required clearances (air spaces) to combustibles when passing through ceilings, walls, roofs, enclosures, attic rafters, or other nearby combustible surfaces. Do not pack air spaces with insulation. Check the appliance manufacturer's instructions for maximum vertical rise of the venting system, and any maximum horizontal off-set limitations.

Step 2. Set the gas appliance in it's desired location. Drop a plum bob down from the ceiling to the position of the appliance flue exit, and mark the location where the vent will penetrate the ceiling.

Drill a small hole at this point. Next, drop a plumb bob from the roof to the hole previously drilled in the ceiling, and mark the spot where the vent will penetrate the roof. (Fig 13) Determine if ceiling joists, roof rafters, or other framing will obstruct the venting system. You may wish to relocate the appliance, or to offset the vent pipe to avoid cutting load-bearing members.

Step 3. To install the Round Ceiling Support / Wall Thimble Cover in a flat

ceiling, cut an 11" x 11" square hole in the ceiling, centered on the hole drilled in Step 2 (unless otherwise specified by the appliance manufacturer). Frame the hole as shown in Fig 14.

Step 4. If the Twist-lock Appliance Adaptor has not been installed on the appliance by the manufacturer, install it now in accordance with the appliance instruction manual.

Step 5. Assemble the desired lengths of Black Pipe and Elbows necessary to reach from the Appliance Adaptor up through the Round Ceiling Support. Insure that all Pipe and Elbow connections are in their fully twist-locked position.

Step 6. Cut a hole in the roof centered on the small drill hole placed in the roof in Step 2. The hole should be of sufficient size to meet the minimum requirements for clearance to combustibles, as specified by the appliance manufacturer. Continue to assemble lengths of Pipe and Elbows necessary to reach from the Round Ceiling Support up through the roof line.

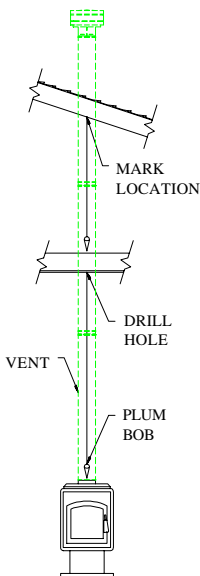

Fig 13

Notes:

(1) If an offset is necessary in the attic to avoid obstructions, it is important to support the vent pipe every 3 feet, to avoid excessive stress on the Elbows, and possible separation. Wall Straps are available for this purpose. (Fig 15)

(2) Whenever possible, use 45° Elbows, instead of 90° Elbows. The 45° Elbow offers less restriction to the flow of flue gases and intake air.

Step 7. Slip the flashing over the Pipe Section(s) protruding through the roof.

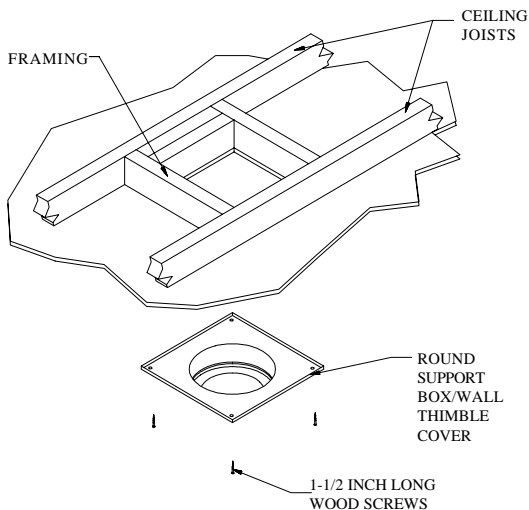

Fig 14

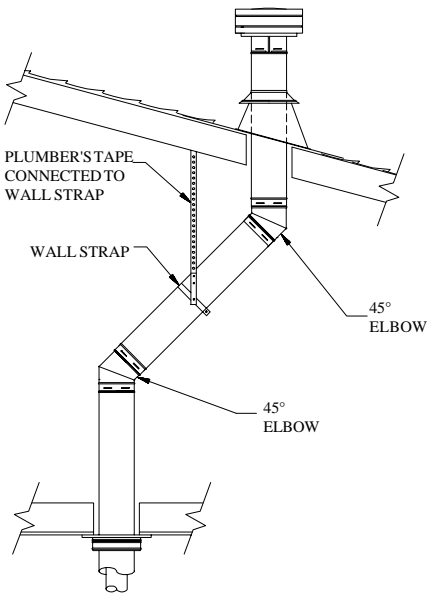

Fig 15

draft, or down-drafting. In these cases, increasing the vent height, or changing the to the High Wind Cap, may solve this problem

Step 9. Slip the Storm Collar over the Pipe, and push it down to the top of the Flashing, as shown in Fig 17. Use non-hardening sealant around the joint between the Storm Collar and the Pipe.

Step 10. Twist lock the Vent Cap onto the last pipe section.

Secure the base of the Flashing to the roof with roofing nails. Use a non-hardening sealant between the uphill edge of the flashing and the roof. Insure the roofing material overlaps the top edge of the Flashing as shown in Fig 17. Verify that you have at least the minimum clearance to combustibles at the roofline.

Step 8. Continue to add Pipe Sections until the height of the pipe (before adding cap) meets the minimum building code requirements described in Fig 16. Note that for steep roof pitches, the vent height must be increased. In high wind conditions, nearby trees, adjoining rooflines, steep pitched roofs, and other similar factors can result in poor

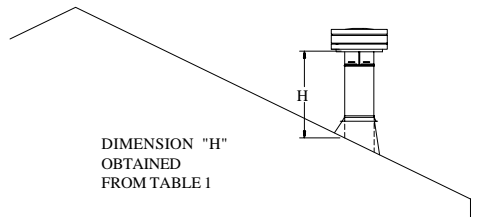

Fig 16

TABLE 1		
ROOF PITCH	MINIMUM HEIGHT	
	FEET	METERS
FLAT TO 7/12	1	0.3
OVER 7/12 TO 8/12	1.5	0.46
OVER 8/12 TO 9/12	2	0.61
OVER 9/12 TO 10/12	2.5	0.76
OVER 10/12 TO 11/12	3.25	0.99
OVER 11/12 TO 12/12	4	1.22
OVER 12/12 TO 14/12	5	1.52
OVER 14/12 TO 16/12	6	1.83
OVER 16/12 TO 18/12	7	2.13
OVER 18/12 TO 20/12	7.5	2.29
OVER 20/12 TO 21/12	8	2.44

Notes:

(1) For multi-story vertical installations, a Ceiling Firestop is required at the second floor, and any subsequent floors. (Fig 18). The opening should be 10.5" x 10.5" and framed similar to the opening in Step 3.

(2) If Vent passes through any occupied areas above the first floor, including closets and storage spaces, it must be enclosed. The enclosure may be framed and sheetrocked with standard construction materials, however consult the appliance manufacturer's installation instructions for the minimum allowable clearance between the outside of the vent pipe, and the combustible surfaces of the enclosure. Do not fill any of the required air spaces with insulation.

CATHEDRAL CEILING INSTALLATION

Step 1. Follow installation Steps 1 and 2 under Vertical Terminations.

Step 2. Using the plumb-bob, mark the centerline of the venting system on the ceiling and drill a small hole through the ceiling and roof at this point. From the roof, locate the drill hole and mark the outline of the Cathedral Ceiling Support Box.

Step 3. Remove shingles or other roof covering as necessary to cut the rectangular hole for the Support Box. Cut the hole 1/8-inch larger than the Support Box outline.

Step 4. Lower the Support Box through the hole in the roof until each side of the bottom of the Support Box protrudes at least 2-inches below the ceiling. (Fig 19). Align the Support Box both vertically and horizontally with a level. Temporarily

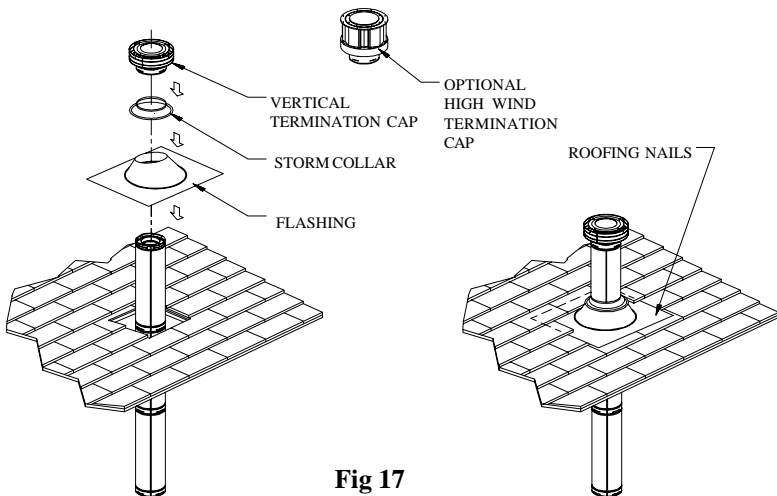

Fig 17

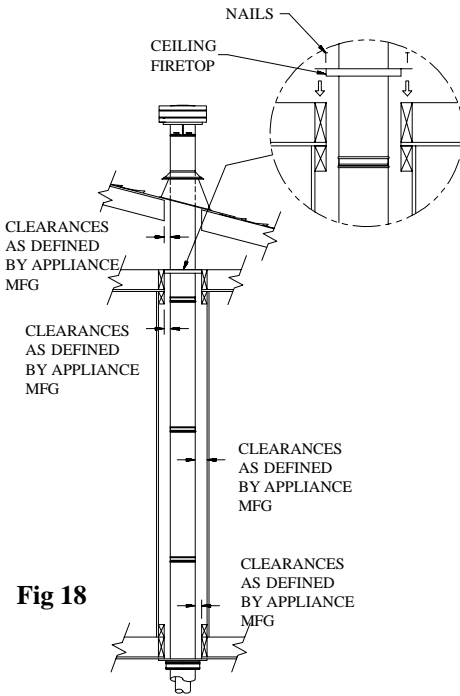

Fig 18

tack the Support Box in place through the inside walls and into the roof sheathing.

Step 5. Using tin snips, cut the Support Box from the top corners down to the roofline, and fold the resulting flaps over the roof sheathing. (Fig 20) Before nailing it to the roof, run a bead of non-hardening sealant around the top edges of the Support Box, to make a seal between the Box and the roof. Clean out any combustible material from inside the Support Box.

Step 6. Follow Steps 4 and 5 of the Vertical Installation Instructions.

Step 7. Place the Support Clamp (provided with the Support Box) inside the Support Box (at the bottom), and secure to the Pipe Section. The Clamp

allows the Support Box to support the weight of the Pipe Sections.

Step 8. Follow Steps 6 through 10 of the Vertical Installation Instructions.

Step 9. Install the black Trim Collar around the outside of the Cathedral Ceiling Support Box. The two pieces of the Trim Collar slide over one another to allow for easy adjustment around the Support Box. Using the six (6) screws provided, secure the four corners and the overlapping sections of the Trim Collar to the ceiling. You may want to pre-drill the holes for the overlapped sections for ease of installation. See Figure 21.

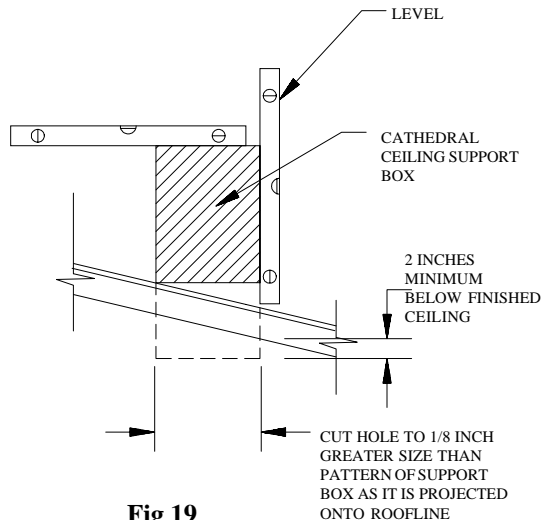

Fig 19

GENERAL MAINTENANCE

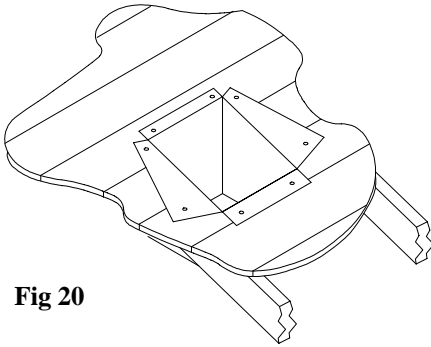

Fig 20

Conduct an inspection of the venting system semi-annually. Recommended areas to inspect are as follows:

1. Check areas of the Venting System which are exposed to the elements for corrosion. These will appear as rust spots or streaks, and in extreme cases, holes. These component should immediately be replaced.

2. Remove the Cap, and shine a flashlight down the Vent. Remove any bird nests, or other foreign material.

3. Check for evidences of excessive condensate, such as water droplets forming in the inner liner, and subsequently dripping out at joints. Continuous condensate can cause corrosion of caps, pipe, and fittings. It may be caused by having excessive lateral runs, too many elbows, and exterior portions of the system being exposed to cold weather.

4. Inspect joints, to verify that no Pipe Sections or Fittings have been disturbed, and consequently loosened. Also check mechanical supports such as Wall Straps, or plumbers' tape for rigidity.

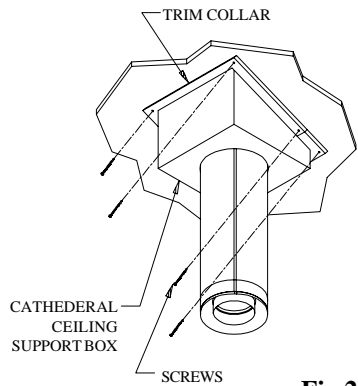

Fig 21

LABELS

All components are labelled with the appropriate identification information. Pipe and fittings which are painted black, have the label placed on the inside of the outer sleeve near the male end.

Other products made by Simpson Dura-Vent:

Dura/Plus Chimney

Dura-Vent Gas Vent (B-Vent)

Dura-Black Single Wall Stovepipe

Dura/Liner Masonry Reliner

DVL Close Clearance Connector Pipe

Dura/Connect Single-Wall Connector for B-Vent

DuraFlex Masonry Reliner for Gas Appliances

Designer Series Accessories



**SIMPSON
DURA-VENT, INC**
PO Box 1510
Vacaville, CA
95688-1510

Vicksburg, MS

(800)-835-4429
(707)-446-4740 (FAX)

Nov. 1997
L953