

L-Vent / Vent System for Pellet and Corn Burning Appliances

Installation Instructions

Covering - General Installation Instructions & Owner's Maintenance Guide

A MAJOR CAUSE OF VENT RELATED FIRES IS FAILURE TO MAINTAIN REQUIRED CLEARANCES (AIR SPACES) TO COMBUSTIBLE MATERIALS. IT IS OF THE UTMOST IMPORTANCE THAT THIS DOUBLE WALL VENT SYSTEM BE INSTALLED ONLY IN ACCORDANCE WITH THESE INSTRUCTIONS.

Read all instructions before beginning the installation. Failure to install this system in accordance with the instructions will void manufacturer's warranty and may result in an unsafe installation. Keep these instructions for future references.

⚠ WARNING
Failure to follow the installation instructions could cause **FIRE, CARBON MONOXIDE POISONING, OR DEATH.** If you are unsure of installation requirements, call the Phone Number listed on the instructions, 1-800-992-8368 or visit www.selkirkcorp.com

1. VENT SYSTEM PARTS AND NUMBERS

Figs. 1,2, 3 and 4 show the names and locations of commonly used Model VP parts. On these and other figures which are present throughout this document, only the last portion of the part number is used. The complete part number is prefixed with I.D. size, system identifier and part identifier.

For Example:

Model VP System

Inside Diameter - - **4 VP-TS** - Standard Tee

Model VP System

Inside Diameter - - **4 VP-60** - 60" Pipe Length

2. SIZES AND APPLICATIONS

Selkirk Metalbestos Model VP L-Vent is manufactured in 3" and 4" I.D. sizes. L-Vents installed in accordance with these instructions comply with National Safety Standards such as NFPA 211.

The Model VP L-Vent System may be used for venting gas or oil fired appliances listed for use with Type L-Vent in addition to Listed pellet and corn burning appliances.

3. MODEL VP SAFETY CERTIFICATION

Model VP has been tested and listed by Underwriters Laboratories, Inc. in accordance with UL641, the Standard for Type L Low Temperature Venting Systems, in addition to certain other applicable requirements from UL103, the Standard for Residential Type and Building Heating Appliance Chimneys. Model VP has also been tested and listed to Canadian Standards ULC-S609 for Low Temperature Vents Type L and ULC/ORD-C441 for Pellet Vents. Model VP is rated for flue temperatures up to 570deg F.

4. MINIMUM CLEARANCE--AIRSPACE ONLY

All Model VP flue gas carrying parts are marked with clearance information as follows:

MAINTAIN MINIMUM 1" AIRSPACE CLEARANCE TO COMBUSTIBLES in the U.S. and MINIMUM 3" AIRSPACE CLEARANCE in Canada. "Combustibles" include framing lumber, drywall, plaster, plywood, paneling and other building materials.

In addition to the airspace clearance specification, each section of vent is marked with an "UP" arrow indicating the intended direction of flow (i.e. end which should be oriented AWAY from the appliance). Auxiliary parts such as combination Ceiling Support/Firestop Spacers, Trim Plates, Flashings and Wall Thimble outer shields are intended to be attached directly to the framing or to ceilings, floors, or walls in accordance with their respective instructions. These parts, which are installed in contact with wood or other combustibles, are designed and tested to assure that they do not overheat at points of contact.

Table 1 gives the proper framing dimensions, which in turn define the proper clearance. Wherever these instructions illustrate the use of a required spacer, thimble or firestop, the purpose of the part is to maintain and assure the proper clearance.

Remember that clearance requirement is AIR SPACE ONLY.

Table 1

Minimum Clearance and Framing Dimensions

Vent Size	Clearance (US)	Framing (US)	Clearance (Canada)	Framing (Canada)
3"	1"	9-1/2" x 9-1/2"	3"	9-1/2" x 9-1/2"
4"	1"	10-1/2" x 10-1/2"	3"	10-1/2" x 10-1/2"

5. ENCLOSURES

The vent system should be enclosed in occupied areas, closets, storage rooms, and accessible attics. Enclosures may be built of ordinary drywall or plywood at the required minimum AIRSPACE CLEARANCE. (See Table 1) There are no special parts to maintain clearance to inside surfaces of walls or enclosures. Therefore, the vent installer should take all necessary precautions to assure that this minimum airspace is maintained.

In unoccupied attics, it is very important to be sure that blown-in or other insulation does not come in contact with the vent system. A full enclosure in the attic should extend to the roof. However, it need only be finished well enough to keep insulation and stored furnishings away from the vent system. NOTE - Enclosures maintaining the minimum airspace clearance are especially important in attics insulated with CELLULOSE type insulation which may be composed of old newspapers and other cellulose materials which are very susceptible to ignition of a fire.

A vent system enclosure is also recommended for any exterior systems and portions extending through unheated areas. This enclosure is helpful in reducing internal condensation, residual buildup from products of combustion and metal deterioration. Also the enclosure, by protecting the vent from cold outdoor temperatures, may improve draft and appliance operation. At the upper end of an outdoor enclosure the vent system should be finished off with a flashing, storm collar and vent cap as described elsewhere in these instructions.

Regardless of the benefits of the exterior enclosure, better vent and appliance operation will be obtained if the vent is located entirely inside the heated portion of the building (except of course for the part above the roof).

6. YOUR CHOICE OF HEATING APPLIANCE

There are three important rules for selecting a gas or pellet burning appliance. FIRST: Look for a label or nameplate attached to the appliance which bears the mark of a well known safety testing organization, such as Underwriters Laboratories, American Gas Association, etc.

SECOND: Don't buy an appliance which is larger than necessary.

THIRD: Look or ask for complete installation, operating and maintenance instructions for the appliance. If you can't get these, buy one that includes all these very important details.

7. APPLIANCE SAFETY

Be sure to follow all details of the instructions provided with your appliance. Especially note and follow recommended installation clearances and operating instructions.

8. VENT SIZE, HEIGHT AND TERMINATION

Before beginning installation of the vent system, be sure that the selected size is adequate for the appliance and the selected height of the Model VP

termination is sufficient to conform to building code requirements and the termination height guidelines given elsewhere in these instructions.

9. A NOTE ABOUT PRODUCTS OF COMBUSTION FROM PELLET BURNING APPLIANCES

One of the most common, visible products of combustion from many pellet burning appliances is a fine, powdery dust which may tend to accumulate near the outlet of the vent and/ or at the joints within the vent. While this material is believed to be non-combustible, it should not be permitted to accumulate within the system since significant accumulation could begin to affect both the vent system's ability to function properly and the heating appliance operation. Accordingly it is recommended that the system be inspected periodically for the build-up and cleaned if necessary. In order to help minimize the accumulation of this powder within the system, each vent section is provided with a hi-temperature fiberglass rope gasket within the annulus of the female end. This gasket helps minimize air movement through joints, thereby enhancing the draft through the vent system and minimizing the powder accumulation.

10. USE OF SEALANTS

(OPTIONAL IN U.S.A. MANDATORY IN CANADA)

Model VP has been listed for use with high temperature silicon sealant applied to the male end and seams of the vent section just prior to installation. This sealant in conjunction with the rope gasket, further reduces air infiltration, minimizing accumulation of the powder.

Vent systems incorporating tee sections, 90 degree elbows and/ or tall heights are most susceptible to the powder accumulation and should be inspected and cleaned more frequently.

Use only high temperature sealants such as Dow Corning's Silastic 732 RTV or Firestop sealant, or comparable, rated for use at a minimum of 450 degrees F (232deg. C).

11. RULES FOR SAFETY DURING INSTALLATION

- Wear safety glasses when sawing, nailing, or using other power tools.
- Wear gloves when handling sheet metal parts with sharp edges.
- Be sure all electrical tools are properly grounded.
- Be very careful when cutting openings and working in the area where electrical wiring is located. Wiring should be secured at least 3" away from the outer surface of any vent section. If wiring must be relocated, have this done by a qualified electrician.
- Ladders, where necessary, should be in good condition and set upon a firm, level surface.

12. VENTING MORE THAN ONE APPLIANCE

In certain instances more than one gas or oil fired appliance may be connected to the same vent system. Be sure to follow the appliance manufacturer's recommendations and local fire and building code requirements if this is planned. **UNDER NO CIRCUMSTANCES** should a pellet or corn burning appliance be connected into the same vent system.

13. SUPPORT

Model VP vent system must be securely supported. Lateral runs are to be supported at least every 5 feet. When offsets are necessary, adequate support above and below the offset is required. In addition it is recommended that each offset elbow be secured with a minimum of two sheet metal screws at the joint. (See "Vent Section Interconnection"). Vertical runs are normally supported by the combination Ceiling Support/ Firestop Spacers. Short vertical vents with less than 6 feet of vertical vent below the flashing may be suspended from the flashing. In such case, the vent may be supported by the storm collar resting on the top of the flashing, using 1/4" long sheet metal screws to attach the storm collar to the vent at the appropriate place. Vents supported only by the flashing must be guyed above or below the roof to withstand snow and wind loads. All vents extending above the roof more than 5 feet must be securely guyed or braced.

14. GENERAL INSTALLATION INSTRUCTIONS

VENT SECTION INTERCONNECTION

Each flue gas carrying section of Model VP is designed with a male and female end coupling. To join sections simply push mating ends together until the locking tabs engage, preventing them from being pulled apart. If additional securement is desired, one or more, maximum 1/4" long sheet metal screws may be used at the joints. Being careful not to drill through the stainless steel inner wall of the vent, first drill a 3/32" hole approximately 3/8" above the line of the joint. Then install the screw(s). **NOTE:** Anytime sections of Model VP are supported only from above, the use of these additional screws is recommended to prevent unintended disengagement of vent sections.

COMMON TYPES OF INSTALLATIONS

Figs. 1 through 4 show four common types of installations of the Model VP vent system. These figures provide a reference for reviewing common applications for the various system parts.

NOTE: See Table 1 for Minimum Clearances

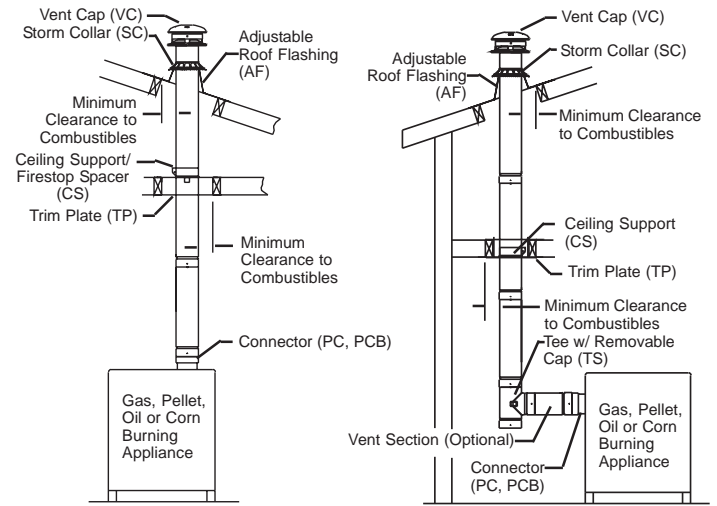

FIG. 1

FIG. 2

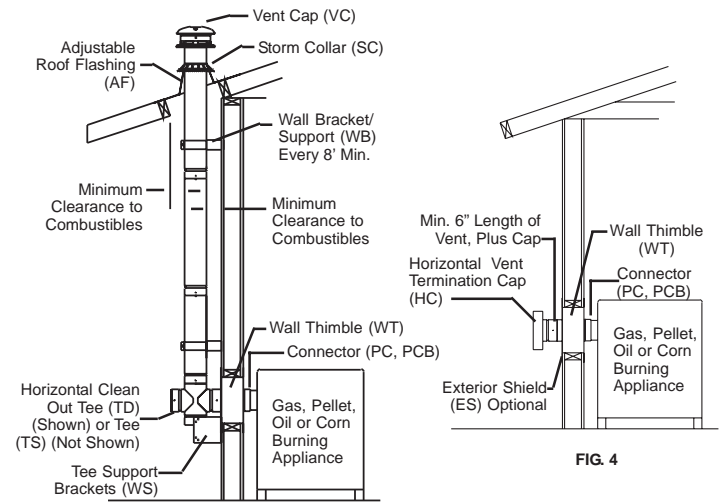

FIG. 3

FIG. 4

INSTRUCTIONS FOR INSTALLING VENT

- Refer to "Common Considerations" section for a list of items that should be taken into consideration before beginning any installation.
- Locate appliance per Manufacturers recommendations, making sure to maintain specified clearances to combustibles.
- Attach Pipe Connector (PC) per section on "Pipe Connector" (See Figs 1-4).
- If the vent planning was to include a vertical rise, a Tee Section (TS) can be used to turn the vent vertical (see Figs 2 & 3). Position tee so that it is vertical, and the cleanout tee cap is at the bottom. Attach tee to vent.
- Connect additional vent sections to route the system out of the building.
- See "Adjustable Length" section for situations where a non-standard length of pipe is necessary.
- Refer to "Wall Bracket Support" (WB) section for instructions for providing support for the vent system (See Fig 3).
- For vertical penetrations see section on "Vertical Penetrations" for proper installation (See Figs 1 & 2).
- For Horizontal Wall penetrations, see section on "Wall Thimble" for proper installation (See Figs 3-4).
- If a Tee and Tee support was included in the planning, see section entitled "Tee and Tee Support" for proper installation (See Fig 3).
- When terminating vertically through the roof, see sections on "Roof Flashing", "Storm Collar", & "Vertical Termination Cap" (See Figs 1-3).
- When terminating horizontally through a wall, See section on "Horizontal Termination Cap" (See Fig 4).

- M. See sections 15 & 16 for installation instructions on painting the product and maintenance requirements.

COMMON CONSIDERATIONS

The following comments apply to all types of installations.

1. Before beginning any installation, select the desired location for the appliance, being sure to maintain the appliance manufacturer's specified minimum clearances. Try to minimize the amount of work by choosing a location where framing members in the walls and floors will not interfere with the intended vent location or the required airspace clearances.
2. Where possible, minimize the length and total number and degree of offsets in your vent system in order to permit the system to vent optimally. Use of too many offsets may result in poor draft and may affect the performance of the appliance. If it is necessary to include many offsets and/or extensive lengths of vent, consider use of an additional joint sealant. (See "Optional Joint Sealant") in order to optimize available draft for the system's configuration.
3. Throughout these instructions, where preparation of an opening for passage of Model VP through walls is referenced, we recommend cutting and FRAMING the opening to the appropriate size. While framing is not necessary in all cases, it is recommended in order to maintain the integrity of the structure and provide sufficient anchoring for fasteners, especially where support assemblies will be installed.
4. Framing of the opening is required for all vertical penetrations where a firestop is specified, in order to provide adequate fire-stopping.
5. Proper planning for your Model VP vent installation will result in greater safety, efficiency and convenience, saving time and money.
6. Use ONLY Selkirk Metalbestos Model VP listed parts.
7. DO NOT INSTALL damaged parts.
8. PERMITS are required in most areas. Contact your local building code and/or fire officials regarding permits, restrictions, and installation inspections in your area BEFORE you begin your installation.

YOUR SPECIFIC INSTALLATION REQUIREMENTS

Now that you have an overview of the system parts and optional types of installations, you are ready to plan an installation to meet your specific needs. We suggest proceeding as follows:

1. Carefully review your options for the installation and select a tentative location and vent system configuration. This may be similar to one or a combination of Figs. 1 through 4.
 2. Review the appliance installation instructions and determine whether the location and vent configuration you selected are suitable, convenient and attainable. Plan to incorporate parts which will facilitate inspection and cleaning.
 3. After you are satisfied with the location and configuration, plan the exact layout, identifying all component parts, sizes and dimensions you will need to complete the installation. Check to insure that you have access to all parts and accessories you will need.
 4. If you have not already obtained the necessary permits for the installation, do so before proceeding further.
 5. Accumulate all the parts you plan to use along with the tools, equipment and supplies you may need to complete your work.
- These may include:
- Eye Protection; Hammer; Gloves; Assorted Nails; Tape Measure; Assorted Wood Screws; Marking Pencil; Ladder; Circular Saw; Plumb Bob; Screwdriver; Razor Knife; Extension Cord; Level; Hand Saw; Pliers; Square; Electric Drill; 1/8" or 3/32" drill bit; Caulking Gun; "Stud Sensor" or similar device (for locating framing) Keyhole; Jig, Sabre or Reciprocating Saw; High Temperature silicon sealant, Non-hardening waterproof mastic or caulking.
 6. If space permits, install the appliance and begin installing the vent system directly at the appliance flue collar and work toward the termination. If space does not permit, plan the exact location of your appliance and determine the exact lengths of system components which will extend between your appliance flue collar and the wall or ceiling you will penetrate. Begin the installation of the vent system at this location and work in each direction until the installation is completed by moving the appliance into position and making the final connection between the appliance flue collar and the pipe connector.
 7. As necessary, refer to these detailed instructions for installation of the various component parts, being careful to maintain the required clearances to combustible construction.
 8. Upon completion of your installation, check to see the exterior portions of the vent systems are properly installed and protected from weather. Check to see that all system components are securely attached and installed in accordance with the instructions.
 9. Install any necessary enclosures in occupied areas and in attics to help insure that the system is not damaged and that the required airspace clearance to combustibles is maintained. (See "Enclosures")

- ## RULES FOR DISTANCES FROM HORIZONTAL EXIT TERMINATIONS
- Before beginning any installation which will result in a vent cap being installed adjacent to the side of a structure:

1. Check to confirm that local fire and safety codes permit this type of installation. If so, install per code requirements.
2. In the absence of overriding local requirements, use the following National Fire Protection Association Standard 211 guidelines for distances from the exit termination to doors, windows, air inlets, etc.:
Terminations shall be located:
 - A. Not less than 3 ft. (0.91 m) above any forced air inlet located within 10 ft. (3m).
 - B. Not less than 4 ft. (1.2m) below, 4 ft. (1.2m) horizontally from, or 1 ft. (305mm) above any door, window or gravity inlet into any building, and
 - C. Not less than 2 ft. (0.6m) from adjacent building and not less than 7 ft. (2.1m) above grade when located adjacent to public walkways.

COMMON VENT SYSTEM PARTS AND THEIR INSTALLATION PIPE CONNECTOR (VP-PC, VP-PCB, VP-MFC, VP-APC)

The Pipe Connector is a ("starter section") fitting used to connect the flue collar of the appliance to the Model VP vent system. Available in black (PCB) or unpainted (PC), the connector consists of a single wall cylindrical piece of stainless steel (which is attached to the flue collar of the appliance) on one end and a short double wall section of vent on the opposite end which incorporates a coupling for attachment to other Model VP vent sections. To install: depending upon the appliance flue collar, insert the Pipe Connector into or over the appliance flue collar and attach with a minimum of two screws. A drill with 3/32" bit may be used to drill through the collar and into the connector.

The Adjustable Pipe Connector (APC) and Multi-Function Connector (MFC) have an adjustable hose clamp on the inlet end to connect to the flue collar without the use of supplemental screws. The MFC is used to connect to and increase a 3" diameter flue collar to 4" diameter vent. To install, apply sealant to the flue collar. Slide the inlet end of the APC or MFC over the flue collar. Tighten the hose clamp on the connector (sealing and securing) the APC or MFC to the appliance flue collar.

ADJUSTABLE LENGTH (VP-EZAJ12)

Adjustable lengths are designed to be telescoped over a fixed length of vent in order to create an assembly of specific length. Being an overall length of 12", the adjustable length may be used in vertical, horizontal or sloped configurations but should not be depended upon to support any lengths of pipe beneath.

To install: Guide the bottom end of the adjustable length down over the upper end of a straight section in such a manner as to let the inner flue of the adjustable length slide inside the flue of the fixed section and the outer wall slide down over the outer wall of the fixed length section. When the desired length is achieved by this combination, install two 1/4" long screws provided through pre-punched holes in the outer. Take care not to pierce inner when drilling outer of VP on lower section to secure the two lengths and prevent slippage. Note - The adjustable length is commonly used in conjunction with a straight section and the pipe connector in order to attain a specific length of vent for adapting the system to a specific placement of the appliance.

WALL THIMBLE (WT)

A Wall Thimble must be used for all through-the-wall installations involving combustible construction. The standard Wall Thimble is designed to accommodate wall thicknesses of 4" to 7" while the "Thick Wall" Thimble will accommodate thicknesses of 6-1/2" to 11-1/2", and may be installed in direct contact with combustible framing, insulation and other materials. See Table 1 for Framing requirements.

NOTE: The WT is shipped in the fully engaged position. Prior to installation, it is necessary to disengage the thimble halves. Disengage by rotating face plates in a counter clockwise direction. (CCW) (unscrew the two halves). (See Fig 5)

To Install:

After preparing the proper sized opening (See Table 1), insert the two halves of the wall thimble from opposite sides of the wall and engage by rotating the face plates in a clockwise (CW) direction until a snug fit is achieved. If a tee section with support brackets is to be installed on one side of the wall penetration, it is recommended to frame the opening. The thimble is now installed and ready to receive a section of vent. Slide vent through Wall Thimble. (See Fig 5)

One VP-WB should be installed 6" to 12" above a tee if the optional tee support is not used and within the first 8' if a tee support is used. Additional VP-WB assemblies should be used at maximum 8' intervals as the vent system is routed up the wall. Wall brackets/ supports may be installed as the individual sections are being installed or they may be pre-installed, centered over a projected center line of the vent system on the wall of the structure.

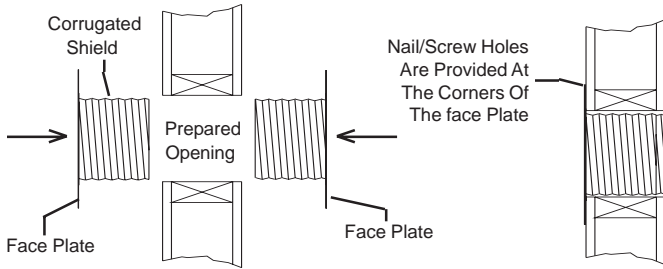

Fig 5

TEE (VP-TS, VP-TD)

Tee sections are designed for use in changing the orientation of the vent from horizontal to vertical and to make cleaning of the system easier than if a 90 deg elbow is used. The tee is provided with a cap on the bottom (VP-TS) and on one side (VP-TD, only) held in place by a friction fit and a screw stop.

To install: Depending upon the particular installation, the tee is either attached to a tee support assembly (see Fig. 3) or simply suspended behind the appliance and supported by a combination of the appliance and support from above (see Fig.2). In either case, common sections of vent are attached to the tee inlet and outlet by simply inserting the mating ends until the tabs engage. In Fig 2 type installation and anytime the tee is supported from above, it is recommended that screws be added to the joints at the inlet and outlet of the tee, in order to prevent unintended joint separation.

TEE SUPPORT (VP-WS)

NOTE: The tee support is optional and should not be installed until the wall thimble has been completed. IF the tee support is not used, a wall bracket/ support MUST be used within 6" to 12" above the tee and the tee inlet and outlet joints must be secured with screws as indicated under "Vent Section Interconnection".

The tee support kit consists of two (2) symmetrical plate brackets (designed to accommodate either a 3" or 4" diameter tee), four (4) wood screws (for attaching the brackets to the wall), and two (2) hex head sheet metal screws (for attaching the support brackets to the tee).

To Install:

1. Referring to Fig. 6, first draw a pencil line on the outer faceplate of the thimble, extending horizontally through the center of the hole.
2. Measure down 5-1/2" and draw a second horizontal line. This line, which is over the center of the lower framing member, will be used to locate the top most screws (location "C" in Fig. 6) for the support brackets.
3. Using the left and right upper edge of the hole in the wall thimble face plate as a starting point, draw vertical lines which extend down to and intersect the lower, horizontal pencil line.
4. Referring to Fig. 6, orient the support brackets as shown and attach each to the bottom left and right side of the tee using a hex head screw routed through the appropriate holes in the support brackets ("A" or "B" from Fig. 6) and into the 1/8" hole provided in each side of the tee, approximately 1" up from the bottom. Rotate brackets to the approximate position shown. Engage screws partially.
5. Insert the pre-selected horizontal section of vent into the inlet of the tee, pushing it in until the tabs snap lock into place.
6. From the outside insert the open end of the horizontal section (with tee attached) through the opening in the wall thimble.
7. Orient the support brackets as indicated and situate so that hole "C" in each support bracket is positioned over the lower horizontal pencil line and the inside (vertical) edge of each bracket is in approximate alignment with respective vertical pencil lines extending down from the edges of the hole in the wall thimble.
8. Once properly situated, secure brackets to wall with four (4) wood screws (provided) using holes "C" and "D". Note that the top hole on the flange of each bracket is not used.
9. Check to see that the correct holes have been used by measuring to verify that the brackets establish the required airspace between the outside wall and the tee, then tighten all fasteners.

WALL BRACKET/ SUPPORT (VP-WB)

The combination Wall Bracket/ Support is designed to provide both lateral and vertical support for a vent system which is installed adjacent to a wall. In addition, properly installed, they provide for the required clearance from the wall.

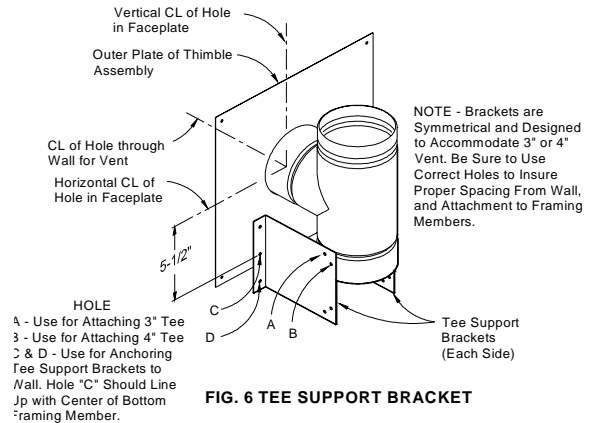

FIG. 6 TEE SUPPORT BRACKET

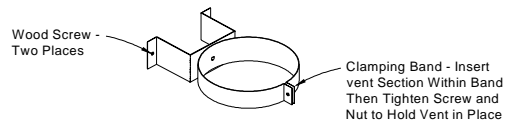

FIG. 7 WALL BRACKET/ SUPPORT

To Install: (Refer to Fig. 7) - After properly locating the bracket on the wall, simply attach the bracket to the wall using the screws provided. A vent section may be inserted within the collar either before or after attachment to the wall. In either case, be sure adjacent vent sections are properly joined together, then simply tighten screw/ nut assembly on collar until collar tightly secures vent section in place.

VERTICAL PENETRATIONS

A Ceiling Support / Firestop Spacer (CS) must be installed where the vent passes through a ceiling or floor joist. The CS provides vertical support for the vent system and maintains the minimum 3" clearance to combustible materials.

If the location where the vent passes through the ceiling is visible, a Trim Plate (TP) may be desired in order to provide a finished look to the penetration. To install: Determine the location where the vent will pass through the ceiling. Prepare an opening in the ceiling (See Table 1 for proper framing dimensions). From the top side of the joist, set the CS plate into the framed opening so that the 4 tabs on the plate extend down into the opening. These tabs help verify that the minimum clearance to framing is established. Nail the CS plate to the framing members (See Fig 8). If installing a TP, center the TP on the ceiling (bottom side) of the opening and secure to the framing members using the fasteners provided. See Support Band section to complete installation.

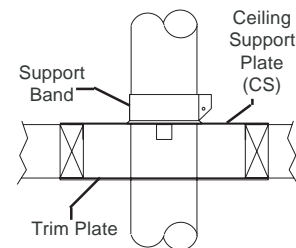

Fig 8

SUPPORT BAND

The Support Band is used to secure the vent pipe to the plate on the CS. After the CS plate is installed, route the vent pipe up through the hole in the CS plate. Position the Support Band so that the larger, flanged edge is to the bottom and slide the support band down over the vent pipe until it is in contact with the CS plate. Using a screwdriver, tighten the bolt on the Support Band to draw the ends together and clamp to the vent pipe (See Figs 8 & 9).

ATTIC INSULATION SHIELD (AIS)

If the vent system is passing through an opened attic space, it is highly recommended to either construct an enclosure or install an Attic Insulation Shield to prevent any debris or blown in insulation from coming in direct contact with the vent. Install the AIS by slipping it down over the vent extending through the attic floor and securing to the floor with nails. Extend the telescoping length to the desired height and secure.

ELBOWS - 45 DEG (VP-45EL), 90 DEG (VP-90EL)

Adjustable 45 (max) and 90 (max) degree elbows are available for use in accommodating unusual offsets and configurations. These optional accessories are designed with the same end couplings as the straight sections in order to facilitate their use anywhere in the system.

ROOF FLASHINGS - TALL CONE (VP-TF), ADJUSTABLE (VP-AF)

Roof flashings are used to provide a transition at the roof through which the vent will pass and to protect the interior of the structure from weather. The VP-TF is intended for use only on flat roofs while the VP-AF is designed for use on roofs having a slope of 0/12 (flat) to 6/12. Flashings are always used in conjunction with a storm collar (VP-SC).

To install: After determining the exact location where the vent assembly will penetrate the roof, cut hole which will provide the required minimum airspace to roof and/ or framing members. After adding vent sections so that the assembly extends up through and is centered within the prepared opening, slide the flashing down over the assembly. On a sloped roof, insert the upper edge and sides of flashing under the roofing material using non-hardening, waterproof mastic around the perimeter of the bottom side and nail to the roof along the upper edge. Do not nail the lower edge, but be sure to include mastic along its bottom edge. On a flat roof, use mastic or caulking around the perimeter of the bottom side, set on roof and nail or screw at the corners. Apply mastic over the heads of the fasteners and an additional bead around the edge.

STORM COLLAR (VP-SC)

The storm collar is used at the top of each flashing to assist in shedding water from the assembly. To Install: Prior to installing the cap and after installing the flashing, install the storm collar by sliding it down over the upper vent section until it rests directly upon the flashing. Apply non-hardening waterproof mastic along the line where the storm collar meets the vent.

VERTICAL TERMINATION CAP (VP-VC)

The VP-VC is intended for use in all installations in which the vent terminates in a vertical orientation. The cap provides necessary protection of the vent system from rain and other elements.

To Install: Simply push the cap down onto the top section of vent until the spring clips engage. No additional attachment is required.

TERMINATION HEIGHT ABOVE ROOF - The termination of Model VP should be located a sufficient distance from the roof so that the discharge opening is at least two (2) feet above the roof surface, or nearby structure.

HORIZONTAL TERMINATION CAP (VP-HC)

The horizontal termination cap is designed specifically for use on installations in which the vent terminates in a horizontal orientation on the outside of a structure. See Fig. 4 and the section which discusses this type installation.

To Install: Slide the cap onto the (minimum 6") section of vent extending out from the wall until the tabs engage. Orient the cap so that the shielded sides of the assembly are on top and bottom while the two outlet openings are facing the sides. NOTE - In order for the cap to provide the intended protection and vent the products of combustion properly, the cap must be installed in the above described orientation. Once installed as intended, carefully drill 3/32" holes in the left and right side of the cap's collar and through (only) the outer wall of the vent section. Drive a 1/4" long sheet metal screw in each hole to prevent the cap from being removed or rotated unintentionally.

The above part descriptions and installation instructions should be referenced as you plan and install your particular installation.

EXIT CAP (VP-EC)

As an alternate to the Horizontal Termination, an Exit Cone Cap is available. This cap is designed to direct flue gases perpendicular to the wall and to increase their velocity, projecting them further away from the building.

Note: When using the Exit Cone Cap, make sure it will be installed so that the hot flue gases do not overheat any of the surrounding area or pose any burn hazard to humans.

To Install: Slide the Exit Cone Cap onto the section of vent extending out from the wall until the lances on the cap engage within the groove on the end of the pipe.

15. PAINTING

To prolong the life and appearance of the outer casing and other parts of the Selkirk Metalbestos Model VP Vent System located outdoors, use proper painting procedure at time of installation. Remove oil and dirt with a solvent. Paint first with a good quality zinc primer or other primer recommended for use on galvanized steel. Next apply an appropriate finish coat. Similar considerations apply for painting of internal components, for aesthetic purposes. Ordinary house paints applied directly to outer casing may not adhere well and do not prevent under film corrosion which leads to paint loosening and peeling. Be sure to use a good primer undercoat and an appropriate finish coat.

16. MAINTENANCE REQUIREMENTS

Refer to the appliance manufacturer's maintenance instructions for recommendations relative to required maintenance of your appliance.

-Model VP vent system requires periodic inspection and cleaning with an appropriately sized brush which will not scratch the inside surface of the flue. DO NOT USE chemical cleaners to clean your venting system.

-Frequency of necessary vent system cleaning will vary with the appliance, vent system configuration and climate. Certain pellet burning appliances or pelletized fuels may give off more fine dust than others.

-In any case it is recommended that the complete assembly be inspected and cleaned (if any buildup has occurred) at the beginning of each heating season and at least monthly thereafter.

-TO INSPECT AND CLEAN . . . Remove the termination cap by removing any screws, then rotating and pulling until it disengages. Remove the tee cap(s) by removing the stop screw and pulling the cap off. Inspect system. If necessary clean by running a brush through the system several times in each direction.

NOTE - Be sure that tee and termination caps are reinstalled and secured when Inspection/ Cleaning is completed and before the system is back in use.

-IN CASE OF FIRE . . . If a fire occurred within the vent system, de-energize the appliance, close all draft controls, evacuate the premises and call the Fire Department. Do not use the appliance or vent system until they have been inspected by a qualified individual and declared suitable for further use.

MODEL VP SYSTEM PARTS

PART	DESCRIPTION
VP-60	5' Length
VP-60B	5' Length - Black
VP-36	3' Length
VP-36B	3' Length - Black
VP-24	2' Length
VP-12	1' Length
VP-EZAJ12	1' Adjustable Length
VP-45EL	.45Deg Elbow
VP-90EL	.90Deg Elbow
VP-AF	Adjustable Roof Flashing
VP-CS	Ceiling Support/ Firestop Spacer
VP-TP	Trim Plate
VP-TD	Double Tee w/Tee Cap
VP-TS	Tee w/Tee Cap
VP-SC	Storm Collar
VP-TF	Tall Cone Roof Flashing
VP-WB	Wall Bracket/ Support
VP-WS	Tee Support
VP-HC	Horizontal Termination Cap
VP-VC	Vertical Termination Cap
VP-WT	Wall Thimble
VP-WTT	Thick Wall Thimble
VP-ES	Exterior Shield
VP-PC	Pipe Connector
VP-PCB	Pipe Connector - Black
VP-A6	MCS Adapter - 6"
VP-A8	MCS Adapter - 8"
3VP-I4	Increaser - 3" to 4"
VP-TP	Trim Plate - Black
VP-EC	Exit Cap

LIMITED LIFETIME WARRANTY

Selkirk Chimney & Venting Products

Selkirk Corporation, ("Selkirk", "we", "us", "our") warrants Selkirk products* to be free from defects in material and workmanship for as long as the original consumer owns the system. For products installed after January 1, 2008, for a period of Ten (10) years from original installation, we will provide replacement product with a similar or like quality of available Selkirk product, **free of charge** excluding any installation costs. From the Eleventh (11) through Fifteenth (15) years we will provide replacement product to the original consumer at a cost of 75% off the published Retail Price in effect on the date the claim is received excluding any installation costs. At expiration of the Fifteen (15) year term, we will provide replacement product to the original consumer at a cost of 50% off the published Retail Price in effect on the date the claim is received excluding any installation costs.

*additional coverage applies to Model CF Chimney

LIMITATIONS:

- Products must be installed for their intended purpose and in accordance with current Selkirk installation instructions.
- Products must be connected to an appliance listed with an accredited testing laboratory.

WARNING: FAILURE TO INSTALL SELKIRK PRODUCTS ACCORDING TO THE MANUFACTURER'S INSTRUCTIONS WILL VOID ALL APPLICABLE WARRANTIES AND MAY RESULT IN FIRE, CARBON MONOXIDE POISONING OR DEATH. SEE OUR SELKIRK INSTALLATION INSTRUCTIONS FOR COMPLETE INSTALLATION PROCEDURES.

WARRANTY COVERAGE:

This warranty covers any substantial defects in material and workmanship in normal use that are found to exist in any of the insulated chimney and venting sections or component parts of your chimney or venting with the exception stated below.

THIS WARRANTY DOES NOT COVER:

- (a) any non-stainless base tee unit mounted or connected to an Insulated Chimney system;
- (b) **costs (labor or otherwise **) associated with either removing a previously installed product, installing a replacement product, transportation or return of a product, or transportation of replacement product;**
- (c) damage to the finish of products caused by the use of improper solvents/chemicals or improper cleaning methods or lack of;
- (d) damage resulting from failure to reasonably clean, care for or maintain products in accordance with our installation instructions/recommendations;
- (e) damage (to products, appliances or structure) on or resulting from

- improper installation or repair, misuse or abuse (including, but not limited to, excessive or improper operating condition), or alteration or adjustment other than in conformity with our installation instructions and specifications, whether performed by a contractor, service company, technician, or yourself;
- (f) any products that have been moved from their original installation site;
- (g) damage caused by burning driftwood, garbage, or any other prohibitive material including non-dry shelled corn fuel with a high level of moisture content higher than 14-15% which has been burned in the appliance served by the system;
- (h) damage that results from accidents such as fire, flood, high winds, "acts of God", or any other contingency beyond our control.

**** Due to the wide variance in installation practices and other conditions beyond our control, we do not guarantee or in any way warrant the installation of Chimney and Venting products.**

CLAIM PROCEDURE:

If you believe that a product is defective, notify us in writing at the following location:

SELKIRK CANADA CORPORATION
P. O. Box 526, Depot 1,
Hamilton, Ontario, Canada, L8L 7X6
ATTN: WARRANTY CLAIMS DEPARTMENT
888.SELKIRK (735.5475), Fax: 866.835.9624
www.selkirkcanada.com

SELKIRK CORPORATION
P. O. Box 831959,
Richardson, Texas, 75240
ATTN: WARRANTY CLAIMS DEPARTMENT
800.992.VENT (8368), Fax: 877.393.4145
www.selkirkcorp.com

Notification should include a description of the product, model and serial number (if applicable) and a description of the product defect. Upon receipt of a written claim under this limited warranty and evidence of the date of purchase or installation, at our option and in our sole discretion, we will provide replacement product with similar or like quality of available Selkirk product excluding any installation costs. Selkirk Corporation reserves the right to inspect or investigate any warranty claims prior to determining whether to provide replacement product. If, as determined by Selkirk Corporation, repair or replacement of the product is not commercially practicable or cannot be completed in a timely manner, we may refund the purchase price paid for the product, prorated to the terms of this warranty, upon verification by providing a copy of your invoice or receipt of bill of sale.

Selkirk products covered under this warranty:
model AFCL, ALT, BV, DSP, DT, DWC, DWS, EV, FC (JSC), GT, GTL, HT, LV, PL, QC, RV, SC (JM), SFCL, SL, SPR, ST, UT, UTL, VP, WV



Selkirk Corporation
1301 W. Pres. George Bush Highway
Richardson, TX 75080-1139
Toll Free: 1.800.992.VENT (8368)

www.selkirkcorp.com

Selkirk Canada Corporation
P.O. Box 526, Depot 1
Hamilton, ON L8L 7X6
Toll Free: 1.888.SELKIRK (735.5475)

0015080-0908

NorthlineExpress.com

http://www.northlineexpress.com

Toll-Free 1-866-667-8454